

ÚZORSY ČERTEŽNÝCH NRV-063

WIDOK 3D



PRODUCT DRAWING RELEASE

Last Modification (geometry): 28/08/2009 00:00

Datasheet creation date: 21/06/2015 10:41

PRODUCT DESCRIPTION:

Worm reduction unit with input shaft

PRODUCT TYPE: NRV

CONFIGURATION & DIMENSIONAL VALUES

GR Size	063
RAP Ratio	7.5
ENTRNRV Input shaft (d*I)	19x40
ACU Output hole shaft (d)	25
VB Double input shaft	NO
TFU Output flange dimension (d)	NO
DFU Output flange dimension (d)	-
PFU Output flange position	-
AL Output hole shaft (d)	NO
PAL Output shaft position gear unit 2	-
BR Torque arm	NO
PBR Torque arm position	-
CAP Cover	NO
A	100
B	40
BB	8
B1	6
D	25(28)
D1	19
F	M6
G1	112
G2	90
G3	75
H	72
I	63
K	85
KE	M8*14(8)
L	103
M	95
N	80
N1	53

PRODUCT DRAWING RELEASE

Last Modification (geometry): 28/08/2009 00:00

Datasheet creation date: 21/06/2015 10:41

PRODUCT DESCRIPTION:

Worm reduction unit with input shaft

PRODUCT TYPE: NRV

CONFIGURATION & DIMENSIONAL VALUES

O	8.5
P	110
Q	80
R	102
S	8
T	36
TT	28.3(31.3)
T1	21.5
V	50
W	45°

PRODUCT DRAWING RELEASE

Last Modification (geometry): 28/08/2009 00:00

Datasheet creation date: 21/06/2015 10:41

2D VIEW PRA

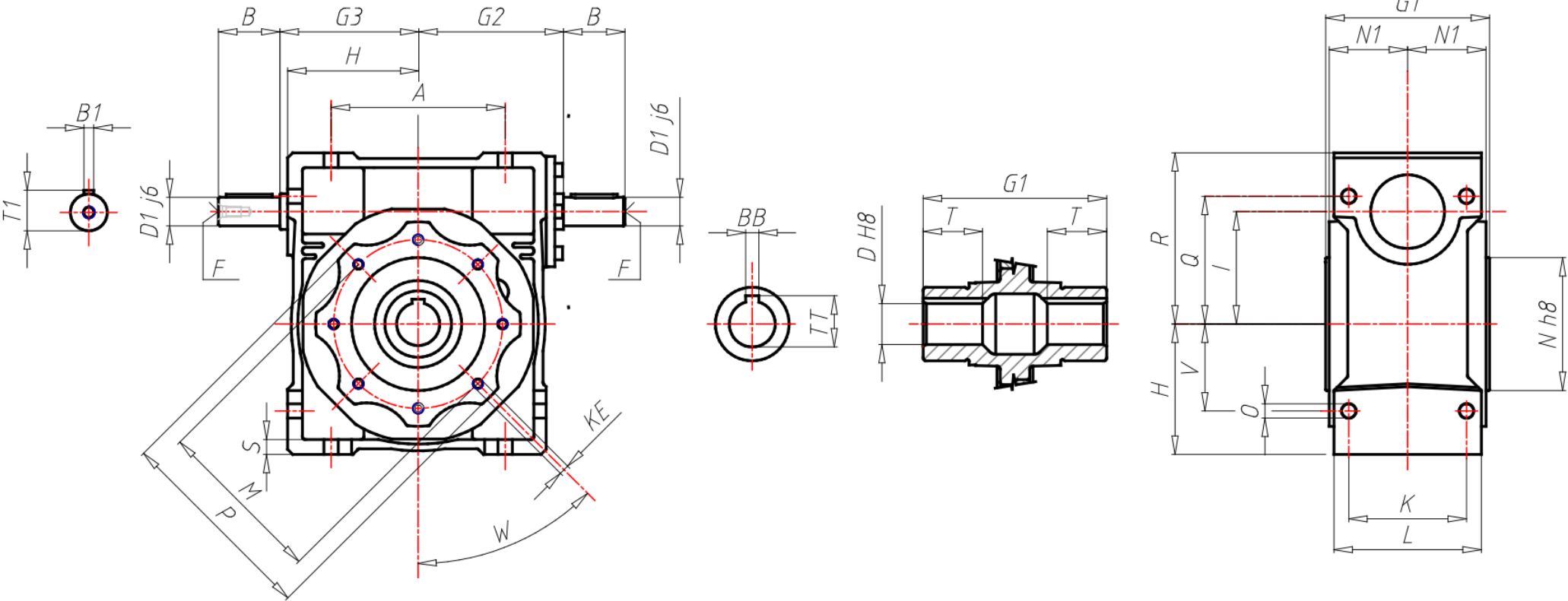

PRODUCT DESCRIPTION:

Worm reduction unit with input shaft

PRODUCT TYPE: NRV

2D VIEW ACCESSORIES

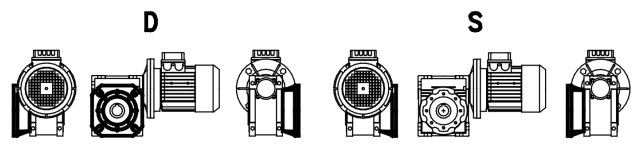
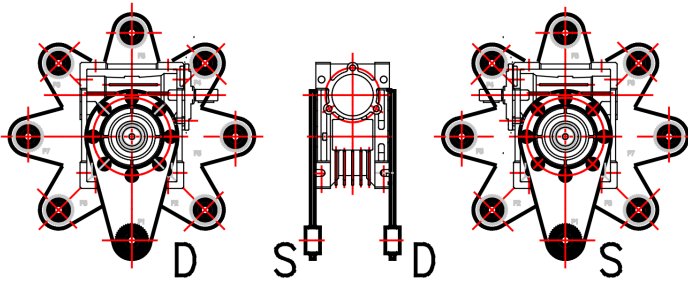

PRODUCT DRAWING RELEASE

Last Modification (geometry): 28/08/2009 00:00

Datasheet creation date: 21/06/2015 10:41